



RIVERSTONE

ARCHITECTURAL DESIGN GUIDELINES &

CONSTRUCTION STANDARDS

City of Star, State of Idaho
County of Ada, State of Idaho



Effective: July 14, 2020
Amended: October 26, 2021

TABLE OF CONTENTS

I.	INTRODUCTION	4
II.	SUBMITTAL AND APPROVAL PROCEDURES	6
	A. Submittal Requirements	6
	B. Notification of Action	8
	C. Expiration of Approval	8
	D. Resubmittals and Substantially Revised Submittals.....	8
	E. Alterations to an Approved Submittal.....	8
	F. Construction Inspections.....	9
	G. Enforcement.....	9
III.	DESIGN CONCEPT.....	10
	A. Guiding Principles	10
	B. Inspiration.....	10
IV.	DESIGN GUIDELINES.....	16
	A. Lot Types	16
	B. Setbacks.....	16
	C. Driveways	17
	D. Minimum Square Feet	17
	E. Exterior Elevations.....	17
	F. Exterior Finishes and Colors.....	18
	G. Solar Panels.....	20
	H. Rain Gutters and Downspouts.....	20
	I. Fascia & Trim.....	20
	J. Architectural Detail/Accents.....	20
	K. Chimneys.....	20
	L. Garages, General.....	20
	M. RV Garages & Tall Garage Doors	22
	N. Detached Storage Structures.....	23
	O. Fences	23
	P. Dog Runs	25
	Q. Patios	25
	R. Landscaping of Small, Large, and Estate Lots	25
	S. Landscaping of Cluster Lots	27
	T. Lake Front Lots.....	30
	U. Lakes, Generally	32
	V. Boulder Retaining Walls	32
	W. Exterior Lighting	33
	X. Mailboxes	33
	Y. Miscellaneous Equipment and Signage	33
V.	CONSTRUCTION STANDARDS	35
	A. Condition of Lot.....	35
	B. Excavation	35
	C. Elevation of Foundations	35
	D. Timeline to Complete Construction.....	35
	E. Lot Drainage	36
	F. Construction Standards and Jobsite Maintenance	36
	G. Complaints.....	38
	EXHIBIT A. VIEW FENCE.....	39

EXHIBIT B. BUILDER/OWNER SCREEN FENCE	40
EXHIBIT C. DEMI-SCREEN FENCE	41
EXHIBIT D. DEVELOPER SCREEN FENCE	42
EXHIBIT E. FENCE PLAN BY PHASE.....	43
EXHIBIT F. DIRECT ENTRY LAKE FRONT LOTS BY PHASE.....	47
EXHIBIT G. ROCK COLOR/TYPE & BOULDER WALL DESIGN EXAMPLES.....	48
EXHIBIT H. LAKE EDGE IMPROVEMENTS	49
EXHIBIT I. POND WATER LEVEL ILLUSTRATIONS & TYPICAL CROSS-SECTION	52
ATTACHMENT 1. APPLICATION FOR DESIGN REVIEW.....	55

I. INTRODUCTION

These Architectural Design Guidelines and Construction Standards (“**Design Guidelines**”) are to be used as guidelines for the Owner and builder in preparing plans and specifications for any proposed Improvement (as defined below), construction, or installation within the Riverstone neighborhood and for maintaining an orderly construction environment. These guidelines are used by the Architectural Reviewer in conjunction with the Declaration. The Riverstone neighborhood will be comprised of various individual areas, each of which may have similar but varying requirements. The Architectural Reviewer reserves the right to grant variances or modify these standards as it deems appropriate and in accordance with the Declaration.

The Master Declaration of Covenants, Conditions, and Restrictions for Moon Valley Subdivision, recorded as Document No. 2020-095409, Official Records of Ada County, Idaho, as amended, (the “**Declaration**”) provides that no Owner may commence the construction of any Improvement (as defined below) without the prior written approval of the “**Architectural Reviewer**”, which shall mean the Architectural Control Committee or ACC as defined in the Declaration. Pursuant to the Declaration, M3 ID MOON VALLEY, L.L.C., an Arizona limited liability company (“**Declarant**”) or Declarant’s appointee or assigns, retains the right to appoint all individuals comprising the Architectural Reviewer until one hundred percent (100%) of the Property has been developed and conveyed to Owners other than builders, unless such right is surrendered prior to such time in accordance with the provisions in the Declaration. As long as the Declarant retains such right, the Architectural Reviewer shall in no event be a committee created by or appointed by the Board or the Riverstone Homeowners Association, LLC, an Idaho nonprofit corporation (“**Riverstone HOA**”).

The Architectural Reviewer will not be required to review any plans until a complete review package, as required by the Declaration and these Design Guidelines, is assembled and submitted to the Architectural Reviewer. The Declaration outlines other specific requirements governing architectural control imposed by the Architectural Reviewer which are not repeated in these Design Guidelines, and which bind each and every Owner. The Architectural Reviewer has the authority to adopt such additional or alternate procedural and substantive rules and guidelines as it may deem necessary or appropriate in connection with exercising its rights hereunder.

The approval of the Architectural Reviewer of any plans or specifications for any work done or proposed in connection with any matter requiring the approval or consent of the Architectural Reviewer will not be deemed to constitute a waiver of any right to withhold approval or consent as to any plans and specifications on any other matter, subsequently or additionally submitted for approval by the same or a different person, nor will such approval or consent be deemed to establish a precedent for future approvals by the Architectural Reviewer.

The Architectural Reviewer may grant variances from compliance with any provisions in these Design Guidelines, when, in the opinion of the Architectural Reviewer, in its sole and absolute discretion, such variance is justified. All variances granted will be evidenced in writing to the builder or Owner. The granting of such a variance will in not operate to waive or amend

any of the terms and provisions hereunder for any purpose, except as to the particular property and the particular instance covered by the variance, and such variance will not be considered to establish a precedent for any future waiver, modification, or amendment to these Design Guidelines.

The Architectural Reviewer is not responsible for: (i) errors in or omissions from the plans and specifications submitted for architectural review; (ii) supervising construction for the Owner's compliance with approved plans and specifications; or (iii) the compliance of the Owner's plans and specifications with applicable governmental statutes, codes, and ordinances, and municipal, county, state, and federal laws.

As used in these Design Guidelines, "**Improvement**" shall mean any and all physical enhancements and alterations within the community, including grading, clearing, removal of trees, site work, utilities, landscaping, irrigation, trails, hardscape, exterior lighting, alteration of drainage flow, drainage facilities, detention/retention ponds, water features, fences, walls, signage, and every structure and all appurtenances of every type and kind, whether temporary or permanent in nature, including, but not limited to, buildings, outbuildings, storage sheds, patios, tennis courts, sport courts, recreational facilities, swimming pools, putting greens, garages, driveways, parking areas and/or facilities, storage buildings, sidewalks, fences, gates, screening walls, retaining walls, stairs, patios, decks, walkways, landscaping, mailboxes, awnings, exterior air conditioning equipment or fixtures, exterior lighting fixtures, water softener fixtures or equipment, poles, pumps, wells, tanks, reservoirs, pipes, lines, meters, antennas, towers and other facilities used in connection with water, sewer, gas, electric, telephone, regular or cable television, or other utilities.

Capitalized words used in these Design Guidelines, but not otherwise defined herein shall have the same meaning ascribed to such terms in the Declaration.

II. SUBMITTAL AND APPROVAL PROCEDURES

A. Submittal Requirements. All submittals shall include the plans, specifications, application, and other information described below, as may be applicable. Construction may not commence until written approval is granted by the Architectural Reviewer.

The submittal plans and materials shall include specifications, dimensions, a legend of all symbols and abbreviations, and other applicable information necessary to perform such a review. Elevation views shall be provided for any proposed vertical Improvements (e.g. built-in BBQ, water feature).

The items listed below shall be digitally submitted to the Architectural Reviewer for approval (e.g. pdf, jpeg). The Architectural Reviewer may request physical samples at and/or additional material to be submitted at its discretion.

1. Application. Each submittal shall be accompanied by a completed design review application and checklist adopted by the Architectural Reviewer, (the “**Application**”), attached to these Design Guidelines as Attachment 1.
2. Site Plan. Show the Building Lot (“**Lot**”) boundaries, the proposed location of all Improvements (including, but not limited to, all structures, driveways, sidewalks, fences, dog runs, patios, decks, outdoor lighting, utility meters, mechanical equipment, etc.), all easements, and all proposed setbacks. Include a roof plan as part of the site plan if a separate roof plan is not submitted. Use arrows to indicate the proposed grading and drainage flow directions off of the Lot and away from adjacent Lots. The Architectural Reviewer may require a separate grading and drainage plan be provided. (Minimum scale of 1/8” = 1’-0”.)
3. Grading Plan. A separate grading plan must be provided in conjunction with an architectural submittal as well as with a landscape submittal for any Lake Front Lot (as defined below in *Section IV.T*). Overlay the proposed grades over the existing grades on a Lot plan showing all boundaries, easements, and applicable setbacks. Use arrows to indicate the proposed grading and drainage flow directions off of the Lot and away from adjacent Lots. (Minimum scale of 1/8” = 1’-0”.)
4. Roof Plan(s). Depict roof masses, ridgelines, and roof pitches including pertinent dimensions (e.g. gable span, overhang depths) if not provided elsewhere. Show the locations of any roof drains or scuppers, as applicable. The roof plan may be included on the site plan in lieu of a separate roof plan. (Minimum scale of 1/8” = 1’-0”.)
5. Floor Plan(s). Include the per floor square feet and total finished square feet of the residence, exclusive of garages, covered patios, storage areas, etc. Provide exterior dimensions on all floor plans. (Minimum scale of 1/4” = 1’-0”.)

6. Building Elevations. Illustrate front, rear and side views, showing the maximum building height and include proposed exterior finish material descriptions. (Minimum scale of 1/8" = 1'-0".)

7. Specifications. Include the specifications and descriptions of any proposed exterior materials, finishes, equipment, etc.

8. Exterior Materials and Colors. Include digital samples of the color of proposed exterior material colors, (e.g. paint, stain). Samples of all other materials (e.g. brick, stone) shall be shown on the elevations. All proposed exterior materials and colors shall be identified by name, number, color, and manufacturer. The Architectural Reviewer may request physical samples of any proposed exterior colors or materials in which case the submittal will not be considered complete until all requested materials have been received.

9. Landscape Plan. Show the proposed landscape and hardscape including dimensions and any proposed fencing and include a legend of the plant types, sizes, and quantities. A legend shall be included for plant types, sizes and quantities. Elevation views of each side shall be included for any vertical Improvement not reflected elsewhere in the submittal. Use arrows to indicate the proposed grading and drainage away from the proposed residence and adjacent Lots. It is preferred that the landscape plan be submitted with the initial architectural plan submittal, but it may be submitted up to sixty (60) days after the initial submittal. (Minimum scale of 1/8" = 1'-0".)

10. Design Review Fees. An initial design review fee of Three Hundred Fifty and No/100 Dollars (\$350.00) shall be paid to the Architectural Reviewer at the close of escrow for such Lot. If, for any reason, the initial design review fee was not paid at close of escrow for such Lot, then the applicable fee shall be paid at the time of the submittal. All design review fees are immediately non-refundable.

An additional design review fee of One Hundred Fifty and No/100 Dollars (\$150.00) shall be due with the following types of submittals and payable to Declarant:

- (i) A Substantially Revised Submittal as defined in *Section II.D* below, and
- (ii) An Alteration Submittal to alter a previously approved submittal as described in *Section II.E* below.

All subsequent Owner submittals and inquiries after the residence and landscape are completed shall be made to the community manager.

All initial Lot builder submittals and inquiries shall be made to:

The Riverstone Architectural Reviewer

c/o Rebekah Hosier

submittals@m3companiesllc.com

602.385.1662

An online repository may be available for digital submittal uploads. Please inquire with the Architectural Reviewer for additional information if desired.

B. Notification of Action. The Owner or builder shall be notified of the decision of the Architectural Reviewer within ten (10) business days of receipt of a complete submittal. The Architectural Reviewer may request additional information or materials and a submittal will not be considered complete until all requested items have been received. Revisions required by the Architectural Reviewer must be resubmitted and reviewed by the Architectural Reviewer prior to issuance of a formal approval unless the revisions are noted as a condition of approval on the Architectural Reviewer approval letter. Should notification of the Architectural Reviewer's decision not be received within ten (10) business days, it does not mean, nor may be construed to mean, the submittal was approved.

C. Expiration of Approval. The approval of the Architectural Reviewer shall be valid for a period of one (1) year at which time it shall expire.

D. Resubmittals and Substantially Revised Submittals. The Architectural Reviewer will review one (1) resubmittal from an Owner or builder, if necessary, following the first formal review and response. After the resubmittal has been reviewed and the builder or Owner has been notified of the decision regarding such resubmittal, the Architectural Reviewer's approval or denial shall be considered final.

If a submittal and subsequent resubmittal are both denied, the Architectural Reviewer will not perform any additional reviews unless the proposed Improvements are substantially revised. Provided the proposed Improvements are substantially revised, the revised designs shall be submitted for review as a "**Substantially Revised Submittal**" and will be subject to an additional review fee as outlined in *Section II.A.10* above. Any Substantially Revised Submittal must include all applicable plans, specifications and submittal requirements set forth herein.

E. Alterations to an Approved Submittal. Proposed alterations or modifications to a previously approved submittal must be submitted as an "**Alteration Submittal**" to the Architectural Reviewer, and written approval from the Architectural Reviewer must be received prior to starting such work. Alteration Submittals must include the applicable plans, specifications and submittal requirements set forth herein and shall clearly identify those elements proposed to be altered or modified. Each Alteration Submittal will be subject to an additional review fee described in *Section II.A.10* above.

F. Construction Inspections. The Architectural Reviewer may make a physical on-site inspection during or at the completion of construction to verify compliance with the approved submittal.

G. Enforcement. If the Architectural Reviewer finds that the Improvements were not done in substantial compliance with the approved submittal corrective measures shall be taken as outlined in the Declaration, including, but not limited to, stopping construction and making physical changes to bring the Improvements into compliance with the approved plans.

III. DESIGN CONCEPT

A. Guiding Principles. Each home shall be designed for 360-degree viewing; all building facades are valued and should be designed with attention to detail. Aesthetically pleasing homes are not defined by the quality of materials alone but also by the quality of the design.

Homes at end conditions with greater visibility from common areas, streets, and/or the club or other amenities may be required to include rear and side elevations with enhanced architectural design elements.

Architectural styles should be either a variant of modern mountain architecture or a complementary style of architecture with modern elements and should be consistent with local environs.

Whenever feasible, designs should:

- (i) Include unique forms,
- (ii) Integrate natural local materials (e.g. stone),
- (iii) Maximize natural light through expansive use of glass,
- (iv) Create indoor / outdoor living spaces that flow together, and
- (v) Meld with the landscape and/or terrain.

B. Inspiration. These guidelines have been created to allow creativity and flexibility while maintaining the spirit and vision at Riverstone. The following images are intended to provide inspiration for the design and creation of architectural plans for use within Riverstone.











IV. DESIGN GUIDELINES

A. **Lot Types.** For the purposes of design review, Lots are divided into the following types:

- (i) **“Cluster Lot”**: Lots with a shared drive in areas designated as a cluster subdivision, (typically, 55’ or 65’ wide);
- (ii) **“Small Lot”**: Less than or equal to 55’ wide at the front building setback;
- (iii) **“Large Lot”**: Greater than 55’ but less than 86’ wide at the front building setback; and
- (iv) **“Estate Lot”**: Greater than or equal 86’ wide at the front building setback.

B. **Setbacks.** The minimum setbacks are described below.

1. Residential Setbacks.

Lots less than 5,000 SF, Multi-Family, or Attached	
Front	N/A
Rear	N/A
Side	N/A
Street Side	N/A
Cluster Lot Setback (4 lot cluster on shared driveway)	
Front (to street)	10 feet
Rear	10 feet
Side (interior)	5 feet
To Common Drive	3 feet
Lots between 5,000 SF - 12,000 SF	
Front	10 feet to living or side load garage, 20 feet to garage door
Rear	20 feet
Side	5 feet
Street Side	12 feet
Lots greater than 12,000 SF	
Front	15 feet to living or side load garage, 25 feet to garage door
Rear	30 feet
Side	5 feet single story/ 7.5 feet if 2 story element is more than 50% of side
Street Side	15 feet

2. **Street Side Setbacks with a Common Lot.** If there is additional width on a Lot with a side yard facing a street, where there is a common lot between the street/sidewalk and Lot, the residence shall have the building set back from such property line more than the minimum setback and such area should include additional landscape where adequate space exists.

3. **Street Side Setbacks with no Common Lot.** If there is a Lot with a side yard facing a street, where there is not a common lot between the street/sidewalk and Lot, the residence should be aligned along the opposite side yard setback and any fence adjacent to the street side is to be aligned 5' from the side of the home. The area between the fence and the sidewalk is to include additional landscape, including trees with a maximum spacing of 45', where adequate space exists.

C. **Driveways.** The builder will be responsible for installing a concrete driveway for any Small, Large or Estate Lot. The builder will be responsible for installing a shared asphalt driveway with ribbon curb for the applicable Cluster Lots.

Unless otherwise approved, driveways may not extend past the edges of the garage to which they lead to allow more room for landscaping. Building lots are limited to one driveway cut at the street unless otherwise approved by the Architectural Reviewer.

D. **Minimum Square Feet.** Two-story homes shall have a minimum of 60% of the square footage, including garage, and excluding basements, storage rooms, covered patios, etc. on the first floor. Finished space is exclusive of basements, garages, storage rooms, covered patios, etc.

Each residence shall include a minimum amount of finished square feet based on Lot type, as set forth below.

Minimum Finished Square Feet of Residence				
	Cluster Lot	Small Lot (<=55')	Large Lot (56'-86')	Estate Lot (>=86')
One-Story Plan	1,200	1,600	2,000	2,800
Two-Story Plan	N/A	2,000	2,500	3,400

The Architectural Reviewer may require additional square feet of finish space depending on compatibility with existing homes or otherwise at its discretion.

E. **Exterior Elevations.** The use of honest architectural elements relative to each architectural style is critical. Elements, such as boxed out windows, dormer windows and covered entries, are encouraged. Double gables over the entire width of a three (3) car garage are discouraged. Stacked rooms over garages shall incorporate a change in the front plane of the garage to avoid large, unbroken vertical surfaces. Where siding is used,

batten boards or trim shall be located as inconspicuously and symmetrically as possible. Windows shall be consistent in type, style, trim and proportion. Architectural detailing should be consistent with the architectural style and avoid the appearance of an over or under worked design.

Lots with rear or side elevations that face a street or Common Area are required to provide a higher level of articulation and detailing, including vertical and horizontal offsets along with breaks in the roof plane. The side of a residence on a Cluster Lot adjacent to or facing the street, highly visible common area, or open space should feature detailing, articulation (e.g. jogs in the architecture), and an overall design and appearance equivalent to a typical “front” elevation. Large expanses of flat, unbroken surfaces are not permitted on elevations facing a street or Common Area. Intermediate horizontal bands are encouraged at all two-story elements when consistent with the architectural style. Covered patios and balconies, horizontal offsets, overhangs, and other methods to create visual depth and contrast are encouraged.

Any “standard” (non-custom) floorplan approved for repetitive use should include multiple elevation styles that are substantially different. Similar architectural styles proposed for more than one floorplan shall have substantially different elevations. Elevation styles may be repeated within Riverstone provided a minimum of four (4) Lots with completely different floorplans and/or elevation styles separate the similar layouts and the color schemes are different. However, the Architectural Reviewer may require some additional differentiation between any like floorplans and elevations. The requirements set forth in this paragraph are intended to mitigate undesirable monotony in the community design and finishes. Therefore, a builder submitting for standard plan review should consider the total quantity of floorplans, elevation styles, and color/material schemes necessary to meet these requirements.

Broken roof lines are required. Roof forms, pitches, and overhang depths shall be consistent with the architectural style. Mixing or differing roof pitches on the same elevation is permitted when consistent with the specific architectural style or variant. Steeper front-to-back roof pitches may be required on shorter roof spans if needed to provide greater street presence.

Transitional 2-story or 1-1/2 story residences may be located on corner Lots provided that the single-story portion of the residence is located adjacent to the corner or side street and is approved by the Architectural Reviewer. Two-story residences are prohibited on Lots backing up to or with a side facing a main arterial street, clubhouse, or open space unless the elevation has a single story or stepped appearance.

F. Exterior Finishes and Colors. Exterior finishes should be cohesive with contemporary architecture. Exterior finish materials and colors shall be consistent and continuous on all elevations of a dwelling to achieve a uniform and complete design. Hardie / Tru Lap / Louisiana Pacific or equivalent, wood, stucco, local stone, brick, concrete, ceramic tile, and metal are preferred exterior materials. If ceramic tile is proposed as an exterior finish, it will be subject to higher scrutiny. High quality

manufactured stone and/or other finishes will be considered at the discretion of the Architectural Reviewer.

Architectural and aesthetic balance shall be primary concern in determining placement of materials. All materials will be required to terminate at an inside corner whenever possible or wrap the corners a minimum of thirty-six inches (36"). Materials may be required to extend further in cases where there is a more logical terminus point. Designs are encouraged to use materials to define building forms.

1. Stone, Brick, and Other Finishes. Subject to compatibility with the overall architectural style and design, all residences, except as noted below, shall be required to incorporate brick, stone, stained wood, or other accent materials (e.g. metal, ceramic tile). A minimum of twenty percent (20%) of front elevations that face a street(s) will be required to be stone, brick, stained wood, and/or other accent materials. The requirement for the use of such accent materials on exterior elevations may be waived by the Architectural Reviewer for exceptional design concepts that establish a very high quality through other elements of architectural design. The Architectural Reviewer may require upgraded siding, additional landscaping, or other elements at its discretion.

Materials shall be compatible with the exterior paint colors approved by the Architectural Reviewer. Darker brick shades are encouraged. White or gray brick will be considered when consistent with the architectural style.

2. Siding & Stucco. Proposed siding as a primary finish should be eight inches (8") minimum width. Narrower siding widths will be considered if consistent with the proposed architectural style. Acceptable siding types include Hardie / Tru Lap / Louisiana Pacific or equivalent. Steel, aluminum, or vinyl siding are prohibited. If siding is used on an elevation, it shall be used on all elevations facing a street or common area.

Stucco exteriors shall incorporate appropriate articulation and accents, such as one and on-half inch (1-1/2") deep by six inch (6") wide trim around windows, twelve inches (12") intermediate horizontal bands at 2-story elements, frieze boards, etc. If stucco is used on an elevation it shall be used on all elevations.

3. Exterior Paint Colors. Exterior wall colors and trim colors must be selected for their harmony with each other and the overall aesthetic goals of the community. Rain gutters and downspouts shall match the color of the surface to which they are attached.

Exterior colors of earth tones, warm tones or grays shall be required for the body of the residence. Bright, bold or very dark colors shall be reviewed on a case by case basis by the Architectural Reviewer.

4. **Roof Materials.** Roofs shall be thirty (30) year or better architectural asphalt shingles, slate, concrete tile, or clay tile and must have high-definition ridge caps. In addition, metal roofs or metal accents (e.g. fascia) are encouraged. Roof colors must be black or dark grey unless otherwise approved by the Architectural Reviewer. Other roofing materials are subject to written approval by the Architectural Reviewer.

G. Solar Panels. Solar panel locations must be approved by Architectural Reviewer prior to installation. Panels shall be commercially manufactured and well maintained. Solar panels shall not be visible from the front elevation of the home if possible. Solar panels and associated hardware shall be an integral part of the design of the home. The color of solar panels, frames, and associated hardware shall be black and shall be recess mounted (flush) into the roof structure or low profile and parallel to the roof with no visible piping. If solar panels are proposed, the roofing material shall be of a hue that minimizes the contrast between the roof and the solar panels.

H. Rain Gutters and Downspouts. Rain gutters and downspouts are required on all residences, shall be continuous, and shall be painted to match the color of the surface to which they are attached. The use of chains or copper gutters and downspouts will be considered when appropriate with the architectural style.

I. Fascia & Trim. Roof fascia shall be a minimum of eight inches (8") wide. Certain architectural styles may require wider fascia. Gables shall incorporate stacked trim detailing. Fascia and trim shall be constructed of nominal one inch (1") thick material. Stacking is not required on eaves where gutter covers the additional fascia.

J. Architectural Detail/Accents. Focus should be placed on architectural design that is true to the character or style/variant submitted. Details and accents should represent the historical integrity of each style and should be consistent with the style on all elevations. Over-worked or unrelated detailing is prohibited.

K. Chimneys. Chimneys may be restricted for size and location. All full height chimneys shall have an architectural metal chimney cap that fully encloses the chimney pipes and painted pursuant to the written approval of the Architectural Reviewer.

L. Garages, General. Designs should de-emphasize the garage, and the main living areas of a residence should be visually dominant. Accordingly, builders are encouraged to locate front-loaded garages behind the front of the rest of the home, e.g. livable finished area, side-load garages, and/or front patios. Side load garages are encouraged, and when possible, designs should avoid placing garage doors where they are visible from the street. Side loaded garages on Lots that are deeper than one hundred thirty feet (130') are highly encouraged, although not required. All garage doors are subject to written approval of the Architectural Reviewer.

All garage doors, including RV or oversize garage doors, should be recessed a minimum of six inches (6") from the face of the garage. When feasible, a minimum garage

door recess of twelve inches (12”) from the garage face is recommended. Garage doors are to have detailing that is consistent with the architectural style and design of the residence. Interiors of garages shall be sheet rocked, taped, sanded, and painted or sheet rocked, taped sanded and textured. Trim around doors and windows shall be painted.

If a front-load garage extends in front of the rest of the home, enhanced architecture will be required. Similarly, enhanced architecture will be required if front load garages take up more than half of the width of the front of the residence. Taller garages will require a greater setback from the other garages as described below.

Garages on Small or Cluster Lots shall be limited to a single two-car garage door or two single-car garage doors. Small and Cluster Lots are limited to a maximum garage door height of eight feet (8’). Garages on Large Lots may have a single two-car garage door plus a single one-car garage door, or three one-car garage doors. If a home features three garage bays, the front of at least one of the garage bays should be set back a minimum of eighteen inches (18”) from the face of the other garage(s). If an RV garage is proposed on a Large Lot, typically, only a single additional, one-car garage door will be permitted. Garages on Estate Lots should be side loaded and de-emphasize the garage. The Architectural Reviewer may elect to allow a front facing garage on an Estate Lot if it is set back behind the home and another side loaded garage.

Detached garages are prohibited except on Estate Lots. Detached garages shall be of the same style, exterior materials and detailing as the dwelling and must be proportional to the dwelling. Detached garages are encouraged to avoid placing garage doors where they are visible from the street.

Garage Doors by Lot Type				
	Cluster Lot	Small Lot (≤55’)	Large Lot (56’-86’)	Estate Lot (≥86’)
Max Number of Garage Doors	(1) 2-car garage door, or (2) 1-car garage doors	(1) 2-car garage door and (1) 1-car garage door, or (3) 1-car garage doors	(1) 2-car garage door and (1) 1-car garage door, or (3) 1-car garage doors	Subject to the written approval of the Architectural Reviewer in its sole discretion
Max Standard Garage Door Height	8’	8’	8’	8’
Max RV/Tall Garage Door Height	N/A	N/A	One (1) 10’ / 12’ (See below)	One (1) 10’ / 12’ (See below)
RV Garage Considered	No	No	Yes (See below)	Yes (See below)

M. RV Garages & Tall Garage Doors. Although taller garage doors and RV garages may be considered on certain Lots or Lot types as described herein, this does not guarantee approval. Plans submitted with RV garages will be subject to a more detailed review process and may be denied by the Architectural Reviewer in its sole discretion.

The Architectural Reviewer reserves the right to designate specific Lots on which oversized and/or RV garage doors will be permitted, along with any predetermined conditions, (e.g. maximum height), otherwise, RV or oversize garage doors may be considered on the following Lot types and sizes:

(i) Large Lots that are at least sixty-two feet (62') but less than seventy-five feet (75') wide at the front setback may have a single one-car garage door higher than eight feet (8') up to a maximum height of ten feet (10'), subject to the guidelines below.

(ii) Large Lots that are at least seventy-five feet (75') but less than eighty feet (80') wide at the front setback may have a single one-car garage door higher than eight feet (8') up to a maximum height of twelve feet (12'), subject to the guidelines below.

(iii) Garage doors greater than twelve feet (12') in height, up to a maximum height of fourteen feet (14') will be considered on Lots that are eighty feet (80') or wider at the front setback, subject to the guidelines below.

The below guidelines are key factors the Architectural Reviewer will take into consideration when reviewing submittals for RV garages and/or oversize garage doors. The Architectural Reviewer's review of any proposed RV or oversize garages will be subjective and in the sole discretion of the Architectural Reviewer.

1. For an RV or oversize garage to be considered, it must meet the below minimum setbacks from the front of any other garage on the Lot. Preferably, the front of an RV or oversize garage should not be located in front of the home's livable space or front porch.

(i) Three feet (3') for a garage door taller than eight feet (8') and up to ten-feet (10') in height,

(ii) Five feet (5') for a garage door taller than ten feet (10').

2. A garage door should not be one of the most prominent features on the façade. The intent is to minimize the impact as much as possible by keeping the taller garage door behind both the front of the residence and the eight-foot (8') garage door. If the front of an RV garage or taller garage extends in front of the finished livable area, enhanced architecture will be required.

3. Turning the other garages into side-load garages are encouraged.

4. Incorporating an architectural pop-out with a lower roof line on the side of a tall garage is strongly encouraged and may be required depending on the particular site and proposed location. Tall garages should incorporate other architectural elements to provide visual interest, such as windows, banding at the level of the roof line, etc.
5. Upgraded, architectural garage doors are encouraged.
6. The overall mass and roof shall be integrated with and in harmony with the rest of the residence. The top of the RV garage should not exceed the roof height of the residence.
7. Unless designated otherwise, Lots with RV garages must typically be separated by a minimum of three (3) Lots on the same side of the street and a minimum of two (2) Lots to each side of an opposite Lot, where applicable.
8. If an RV garage is proposed on an end Lot condition adjacent to common area and/or streets, the RV garage shall be located on the side of the Lot opposite such adjacency.

N. Detached Storage Structures. All vehicles, trailers, tools, and equipment shall be stored out of view in enclosed structures. A maximum of one (1) detached storage facility per Lot will be considered, such as a storage shed, provided it is of the same construction, finish, and color as proposed and approved for the residence. Metal storage sheds or other structures that do not reflect the architectural style and quality of the residence on such a Lot are prohibited.

Such a detached storage facility may not exceed two-hundred (200) square feet in area, and detached structures may not be located within three feet (3') of the property line on a Lot. Any such structure shall be placed on a concrete pad in a location approved by the Architectural Reviewer and may not back to a neighboring view fence. Depending on location, additional landscaping may also be required.

The Architectural Reviewer encourages the storage of boats, RV's, camp trailers and other similar vehicles or trailers in offsite storage facilities.

O. Fences. Prior to the construction of any fence, plans shall be submitted as part of the landscape plans to and approved in writing by the Architectural Reviewer. The submittal shall include a site plan showing the location of fencing proposed, including setback dimensions, and designate the type and height of fence proposed. The only fence types permitted are those specified by these Design Guidelines, and no fence may be installed prior to approval by the Architectural Reviewer. Refer to Exhibit A, Exhibit B, and Exhibit C attached to these Design Guidelines for the permitted fencing types for most Builder and Owner installations. The developer may install an alternate style screen fencing shown in Exhibit D in select locations, and where such exists, it may not be replaced with any other type of fencing, including a Builder/Owner style screen fence.

Generally, any developer installed fencing is required to be maintained and/or replaced as necessary with the same type of fence and may not be removed.

1. General fence requirements include:

- (i) Wherever possible, adjoining Lots shall use common corner posts.
- (ii) Fence returns terminating into the side of a house shall be a minimum of four feet (4') behind the front of the residence on the side where the return is located.
- (iii) Transitions in fence height shall be accomplished by stepping, (not angling), the fence top.
- (iv) Where view fence is used along rear lot lines adjacent to common areas, view fence should also be used for a minimum of two fence panels on the adjacent side yard property line.

2. Permitted locations for each fence type are as follows:

- (i) All Lots located adjacent to club, common area, and/or open space, including water features, hillsides, etc. may optionally install view fencing along such rear or side property line(s). Solid fence types are not permitted along such boundaries, except where already installed by the developer.
- (ii) All Lots located adjacent to a street shall install screen fencing or demi-screen fencing along such adjacent side boundary line(s) as shown in Exhibit E.
- (iii) On Estate Lots, the only type of perimeter fence that will be considered is view fence unless otherwise specified by the Architectural Reviewer.
- (iv) Screen fence may be installed on or along side property lines between residential Lots, except where fence styles are limited to view fence as described above in *Section IV.O.1(iv)*.
- (v) Where view fence is opted to be installed along a rear boundary of a Lake Front Lot, the view fence shall be located at the top of the slope leading down to the water, as applicable, and should include a gate to accommodate maintenance access.

Refer to Exhibit E for a depiction of the Fence Plan by Phase. Depending on location, the Architectural Reviewer may require an on-site inspection prior to fence construction.

P. Dog Runs. Dog runs must be approved by the Architectural Reviewer prior to installation. The size and location may be restricted. If approved, they shall be commercially manufactured and well maintained. Coated chain-link, galvanized, and stainless steel are the only approved materials unless constructed of one of the permitted fence styles.

Q. Patios. All residences are required to include covered rear patios. All exterior patios are required to be a minimum of ten feet (10') deep and shall be covered. Covered patios may be a minimum of eight feet (8') deep (or equivalent alternate dimension) where Lot depth is a constraint. Patio covers shall extend to the edges of the patio and be integral to the design and appear as extensions of the architecture of the residence. Patios and covers on corners shall extend past and wrap the corner of the building. All columns must be a minimum size of twelve inches by twelve inches (12" x 12").

R. Landscaping of Small, Large, and Estate Lots. A landscape plan shall be prepared and submitted to the Architectural Reviewer for approval. Although certain minimum standards have been established, additional landscaping is encouraged and may be required by the Architectural Reviewer. The Architectural Reviewer will consider how the proposed landscaping blends with and promoted the overall aesthetics of the site in conjunction with structures. The use of berms and clustered planting groups such as garden beds with trees, shrubs and flowers are encouraged.

Builders and Owners are encouraged to consider adjacent yards when formulating a landscape plan and to the extent practical, shall blend the Improvements with the neighboring yard landscape Improvements, including planters and berms. Exterior mounted utility meters, heat pumps, air conditioners, and other such equipment shall be properly screened from view of the street and surrounding homes by landscaping or fencing.

Landscaping in front, rear, and side yards is required to be completed in accordance with these standards within thirty (30) days of substantial completion of the home, except in the event weather makes installation unfeasible, in which case written waiver from the Architectural Reviewer is required.

1. Trees shall be planted in front yards, corner yards and rear yards according to the following minimum standards:

(i) Deciduous trees shall be 2" caliper or larger and evergreen trees shall be 8' high or higher.

(ii) An ornamental tree or 5 additional 2-gallon shrubs may be substituted for one of the trees required in the front yard if approved by the Architectural Reviewer.

(iii) A Lot on which the residence is required to have an increased side setback as described in *Section IV.B* shall have additional

trees planted within such area along the property line provided the width of the side yard is a minimum of ten (10) feet, and such trees shall have a maximum spacing of forty (40) feet.

MINIMUM TREE QUANTITIES			
	Small Lot (≤55')	Large Lot (56'-86')	Estate Lot (≥86')
Front Yard	2 trees, at least one deciduous tree and one evergreen tree	3 trees, at least one deciduous tree and one evergreen tree	4 trees, at least one deciduous tree and one evergreen tree
Corner Lot Side Yard	See <i>Section IV.R.1(iii)</i> , above		
Rear Yard	1 tree per 1500 square feet of rear yard	1 tree per 1500 square feet of rear yard	1 tree per 1500 square feet of rear yard

2. Shrubs shall be planted in the front yards, corner yards and rear yards according to the following minimum standards:

MINIMUM SHRUB QUANTITIES			
	Small Lot (≤55')	Large Lot (56'-86')	Estate Lot (≥86')
Front Yard	Minimum 18-22, 2 gallon or larger shrubs	Minimum 20-24, 2 gallon or larger shrubs	Minimum 24-28, 2 gallon or larger shrubs
Corner Lot Side Yard	Minimum 12, 2 gallon or larger shrubs	Minimum 14, 2 gallon or larger shrubs	Minimum 16, 2 gallon or larger shrubs
Rear Yard	Minimum 9, 2 gallon or larger shrubs	Minimum 10, 2 gallon or larger shrubs	Minimum 12, 2 gallon or larger shrubs

3. Planter beds planted with shrubs and flowers shall cover a minimum of 25% of the front yard, 20% of the side yard on corner lots, and 15% of the rear yard.

4. Except at planter bed locations or side yards, sod shall be laid throughout (excluding driveways, walks, and patios).

5. Sod or turf grass shall be planted covering a minimum of 50% of the front yard and 50% of the rear yard. Artificial turf is prohibited in front yards.

6. Ground cover used in planter beds shall either be a natural wood or soil product with no dyes or color added, or a grey / dark colored perma bark. Bark or

rock chips used as ground cover in planter beds should be no larger than 1 inch in size.

7. An automatic underground irrigation system shall be installed throughout. Such irrigation system shall include appropriate backflow prevention and utilize zones for landscape with different water demands. Sprinkler systems shall be designed to minimize overspray and are encouraged to incorporate low trajectory spray nozzles.

8. Builders are responsible for installing irrigation and landscaping in the planter strips located between sidewalks and curbs adjacent to their Lot if applicable. One street tree shall be planted every thirty-five (35) feet within the planter strip along each property line or right-of-way that borders such Lot as applicable. For street tree specifications, contact the design review committee. Trees in the planter strip are in addition to minimum standards. Turf grass shall be planted in the planter strip except where the driveway and street trees are located.

9. Landscape grading shall be designed to produce a graceful contouring; harsh geometric shapes and slopes will not be approved. Mounding or contouring used to add interest to the landscaping must be an appropriate scale in relation to the rest of the yard and be sufficiently compacted and covered to prevent erosion. Any imported soil shall be free of weeds and debris and equal to the quality of the existing soil on the Lot. Driveway site coverage shall be minimized to provide additional area for landscaping. Gravel pads for parking of vehicles, trailers, etc. are not acceptable.

10. If a raised patio is proposed as part of the landscape, it must be a minimum of three (3) feet from any property line, and the height may not exceed twenty-four (24) inches in order to be considered.

11. Lots backing to a lake edge must also comply with the standards set forth in Section IV.T below.

12. In no event shall the landscape and/or grading alter the Lot drainage as approved by the City of Star, Idaho. All drainage water must be retained on the Lot or directed to the street; no Lot drainage may be permitted to flow onto or across an adjacent property.

Variances to the landscape requirements set forth herein may be granted in cases such as flag lots or pie shaped lots with narrow street frontages. Extensions for completion of landscaping may be granted when weather conditions hamper landscape construction from December 1 through April 1.

S. Landscaping of Cluster Lots. A cohesive landscape plan shall be developed and submitted to the Architectural Reviewer for each group of Cluster Lots that is accessible from a single shared drive. Although certain minimum standards have been established,

additional landscaping is encouraged and may be required by the Architectural Reviewer. The Architectural Reviewer will consider how the proposed landscaping blends with and promoted the overall aesthetics of the site in conjunction with structures. The use of berms and clustered planting groups such as garden beds with trees, shrubs and flowers are encouraged.

Builders and Owners are encouraged to consider adjacent yards when formulating a landscape plan and to the extent practical, shall blend the Improvements with the neighboring yard landscape Improvements, including planters and berms. Exterior mounted utility meters, heat pumps, air conditioners, and other such equipment shall be properly screened from view of the street and surrounding homes by landscaping or fencing.

Landscaping in front, rear, and side yards of each Cluster Lot shall be completed to these minimum standards within thirty (30) days of substantial completion of the residence on such Cluster Lot, except in the event weather makes installation unfeasible, in which case written waiver from the Architectural Reviewer is required.

1. Trees and shrubs shall be planted in front yards, corner yards and rear yards according to the minimum standards described below.

(i) Deciduous trees shall be 2" caliper or larger and evergreen trees shall be 8' high or higher

(ii) An ornamental tree or 5 additional 2-gallon shrubs may be substituted for one of the trees required in the front yard if approved by the Architectural Reviewer.

(iii) A Lot on which the residence is required to have an increased side setback as described in *Section IV.B* shall have additional trees planted within such area along the property line provided the width of the side yard is a minimum of ten (10) feet, and such trees shall have a maximum spacing of forty (40) feet.

CLUSTER LOT MINIMUM TREE AND SHRUB QUANTITIES		
	Trees	Shrubs
Front Yard	2 trees, one deciduous tree and one evergreen tree.	Minimum 16-20, 2 gallon or larger shrubs
Corner Lot Side Yard	See <i>Section IV.S.1(iii)</i> above	Minimum 10, 2 gallon or larger shrubs
Rear Yard	1 tree per 1500 square feet of rear yard	Minimum 8, 2 gallon or larger shrubs

2. Planter beds planted with shrubs and flowers shall cover a minimum of 25% of the front yard, 20% of the side yard on corner lots, and 15% of the rear yard.
3. Except at planter bed locations or side yards, sod shall be laid throughout (excluding driveways, walks, and patios).
4. Sod or turf grass shall be planted covering a minimum of 50% of the front yard and 50% of the rear yard. Artificial turf is prohibited in front yards.
5. Ground cover on planter beds shall be rock chips no larger than 1 inch in size and match or be substantially similar in appearance to the boulders reflected in Exhibit G.
6. An automatic underground irrigation system shall be installed throughout. Such irrigation system shall include appropriate backflow prevention and utilize zones for landscape with different water demands. Sprinkler systems shall be designed to minimize overspray and are encouraged to incorporate low trajectory spray nozzles.
7. Builders are responsible for installing irrigation and landscaping in the planter strips located between sidewalks and curbs adjacent to their Lot if applicable. One street tree shall be planted every thirty-five (35) feet within the planter strip along each property line or right-of-way that borders such Lot as applicable. For street tree specifications, contact the design review committee. Trees in the planter strip are in addition to minimum standards. Turf grass shall be planted in the planter strip except where the driveway and street trees are located.
8. Landscape grading shall be designed to produce a graceful contouring; harsh geometric shapes and slopes will not be approved. Mounding or contouring used to add interest to the landscaping must be an appropriate scale in relation to the rest of the yard and be sufficiently compacted and covered to prevent erosion. Any imported soil shall be free of weeds and debris and equal to the quality of the existing soil on the Lot. Driveway site coverage shall be minimized to provide additional area for landscaping. Gravel pads for parking of vehicles, trailers, etc. are not acceptable.
9. If a raised patio is proposed as part of the landscape, it must be a minimum of three (3) feet from any property line, and the height may not exceed twenty-four (24) inches in order to be considered.
10. In no event shall the landscape and/or grading of a Lot alter the Lot drainage as approved by the City of Star, Idaho. All drainage water must be retained on the Lot or directed off the Lot in accordance with the approved grading and drainage plans; no Lot drainage may be permitted to flow onto or across any adjacent Lot.

Variances to the landscape requirements above may be granted in cases such as flag lots or pie shaped lots with narrow street frontages. Extensions for completion of landscaping may be granted when weather conditions hamper landscape construction from December 1 through April 1.

T. Lake Front Lots. The rear property line of a Lot may be located along a body of water or “lake”, and where there is no landscaped common area between the Lot and water’s edge, such a Lot may be specifically referred to herein as a “**Lake Front Lot**”. (A Lot with landscaped common area between the Lot and a body of water, would not be considered a Lake Front Lot as it pertains to these Design Guidelines.)

As the Property is developed, certain Lake Front Lots may be permitted entry into a lake directly from the Lot, subject to any applicable rules and restrictions. Refer to Exhibit F identifying by phase any Lake Front Lots where direct entry into a lake is permitted.

A grading plan must be included with (a) the architectural submittal and (b) the landscape submittal for each Lake Front Lot when grade changes are proposed or if requested by the Architectural Reviewer. The Architectural Reviewer may require a grading plan be provided with a submittal for an alteration, reconstruction, modification, and/or addition to the rear yard Improvements, in its discretion.

The overall design of a rear yard should provide a gracious transition between the residence and the water’s edge. Refer to Exhibit H for illustrations of lake edge Improvements and refer to Exhibit I for illustrated approximate high and low water levels.

The standards described below will apply to proposed Improvements near or along the water’s edge on a Lake Front Lot.

1. Retaining Walls. Local, surface select boulders are the preferred material for retaining walls; poured in place concrete will also be considered. Block retaining walls are discouraged but may be approved provided such are designed to be an extension of the residential architecture on the Lot.
2. Beach Areas. A recessed sand “beach front” may be constructed on a Lot, provided it is substantially level and does not exceed 40% of the Lot width at the rear property line. Beach front sand should be natural yellow, tan, or white hues; specialty colors, including black, will not be approved. The sand “beach front” should be setback from the side property line a minimum of five (5) feet.
3. Docks. If direct entry from a Lot into a lake is permitted per Exhibit E, a dock may be considered for such a Lake Front Lot provided the Lot is greater than one-hundred feet (100’) wide at the rear property line meeting the water’s edge. The Architectural Reviewer may adopt a standard style, color, size, or other dock specification(s). A dock may be constructed of wood or composite wood, such as

Trex decking or similar, and should be a natural wood color or other earth tone. White, bright, or very light colors will not be approved.

4. Diving Boards & Slides. Diving boards and/or slides leading into the lake are not permitted.

5. Patios. A patio located near the water's edge is to be harmonious with the lake edge and will be subject to a higher level of scrutiny. Covered structures must be kept within the residential setbacks unless otherwise approved.

6. Water Levels. Water levels are expected to regularly fluctuate by several feet and any vertical portion of a proposed Improvement in or along the water should appear consistent and cohesive both when the water level is high as well as when it is low. Refer to Exhibit I for illustrated approximate high and low water levels.

7. Setbacks and Width. Patios, retaining walls, docks, and other Improvements, excluding landscape, along the water's edge will typically be required to be setback at least five (5) feet from the nearest side property line and be limited to no more than 40% of the Lot width at the rear property line.

8. Shore Rock. The landscape for each Lake Front Lot shall include local river cobble installed along the water's edge, in a 3" to 8" size blend, available from Premier Aggregates in Emmett, ID (208-901-8189). Shoreline cobble must be the specified size range, and a single size or alternate size/range is not permitted. Boulders along the shore and slope are to match the color/appearance of the river cobble.

9. Shore Planter Bed Cover. Ground cover in planter beds along the rear of the Lot is to match the color of the ground cover used in planter areas elsewhere on the Lot and shall be rock chips (perma bark) between 1" and 1-1/2" in size. Bark chips may not be used in planter beds located along the back of Lot and shore.

10. Grasses. Grasses may be planted from the top of the slope down to the edge of the water, which is subject to seasonal fluctuation. Due to the grade of the slope, fescue is recommended.

11. Boulder Retaining Walls. Owners are encouraged to install boulder retaining walls to create raised planter beds along the water behind such Owner's Lake Front Lot. In addition, the developer may have installed or may install boulder retaining walls for raised planter beds along the water behind some, but not all, Lake Front Lots. Where there is a raised boulder planter bed behind a Lake Front Lot, the initial landscape for such Lot must include the planter area behind such Lot to meet the following minimum standards, which are in addition to any other minimum landscape requirements on the Lot:

- (i) At least one tree is to be planted meeting or exceeding the minimum tree size for the type (evergreen or deciduous) as specified in *Section IV.R*;
- (ii) Plant at least one (1) shrub per one-hundred (100) square feet of planter area or a minimum of five (5) shrubs, whichever is greater, and such shrubs shall be two-gallon size or larger;
- (iii) Unplanted areas are to be covered with ground cover as described in *Section IV.T.9* above.

12. **Appearance of Lake Edge.** Each Owner of a Lake Front Lot is responsible for maintaining the water's edge adjacent to or along the Lot in a sightly manner, removing any trash or debris, weed abatement, and replacing rock as necessary.

Direct lake entry will not be allowed from all Lake Front Lots, and where permissible, the accessibility to a lake from a Lot may vary throughout a year and/or change over time. Not all Lake Front Lots will have water's edge along the entirety of the adjacent Lot boundary. If there is any dispute as to whether a Lot is considered a Lake Front Lot or whether direct entry to a lake from a Lot may be permitted, the Architectural Reviewer's decision shall be final, conclusive, and binding.

U. Lakes, Generally. Each Lot Owner must follow all applicable rules and standards set forth by the Association for each individual lake, without exception. Physical entry and/or recreational activities in or on the water, (e.g. swimming, boating, rafting, paddle boarding, kitesurfing, jet-skiing) may be permitted on some, but not all, of the community lakes. Dumping of trash, debris, dirt (to include any spoils from regrading or excavation), or other materials into a body of water is strictly prohibited. Owners may not introduce or allow any foreign substance or additive, including fertilizers, that may alter the water quality to enter any body of water.

V. Boulder Retaining Walls. A well-designed natural boulder retaining wall brings a thoughtful, natural element to a landscape concept. Local, surface select boulders are the preferred material for retaining walls; poured in place concrete will also be considered. Block retaining walls are generally discouraged but may be approved in side yards, or provided such are designed to be an extension of the residential architecture on the Lot. If proposed, boulder retaining walls are to be comprised of surface select boulders to match the boulders shown in Exhibit G. Boulder retaining walls are to be substantially similar in design and appearance those seen in Exhibit G. General design principles for boulder retaining walls include:

1. Locate each rock to have a minimum of three bearing points, two in front and one in back;
2. Place each rock so it is in contact with at least two rocks below it;
3. Avoid continuous vertical seams or "columns" of rocks;

4. Avoid continuous horizontal planes in the rockery;
5. Use larger base rocks than used in the upper rocks;
6. Incline rocks back into the slope;
7. Use smaller rocks (“chink rocks”) to fill in voids; and
8. Select rocks free from obvious signs of distress, (e.g. fracturing, disintegrating).

Where boulders are used for slope stabilization, the boulders must be naturally spaced and installed so that the lower circumference is in contact with the grade. Additionally, plants that have a strong root system to help lock soil into place should be incorporated around and between boulders, such as approved vines, grasses, and annual flowering plants.

All retaining walls should be designed to accommodate proper lot drainage and control surface water as necessary. Each Owner is solely responsible for obtaining any engineering and/or governmental approvals that may be necessary.

W. Exterior Lighting. Exterior lighting that is visible from streets, neighboring lots or common areas must have a concealed light source (e.g. covered, shielded) and shall not illuminate neighboring properties. Exterior light fixtures may cast light upward only if they are located under a roof and the beam of light does not extend beyond such roof. Exterior lighting shall be harmonious with the building design. Individual lights are limited to 100 watts. All exterior lighting must be identified on the submittal and is subject to approval by the Architectural Reviewer.

Exterior security lighting will be permitted provided the following standards are met:

1. Security lighting shall be limited to lighting that is triggered by motion on such Lot and may not be triggered by motion on neighboring properties.
2. Such lighting shall not be directed at any neighboring properties and shall be mounted no higher than ten feet (10') above ground.
3. The motion detector shall be programmed to shut off the light(s) no longer than five (5) minutes after motion is detected and the light has been illuminated.

X. Mailboxes. Mailboxes are not permitted on residential Lots. Community mailboxes will be provided by developer.

Y. Miscellaneous Equipment and Signage.

1. Satellite Dish. A satellite dish should be located in consideration of neighbors and potential views. Wherever possible, the satellite dish should be installed on a

rear corner of the home, in a location selected to minimize visibility from common areas and streets. Satellite dishes are prohibited on the front of the home or within the front yard. If mounted on a building, the top of the satellite dish may not exceed the highest part of the nearest roof. In the absence of adequate signal in such a location described, the Owner may request approval for an alternate location.

2. Basketball Equipment. Basketball backboards are not permitted on the roof or walls of the residence. Basketball hoops with glass or plexiglass backboards may be installed on fixed poles adjacent to a driveway but are encouraged to be installed in less prominent areas such as rear or side yards. Moveable basketball hoops are not permitted in front yards.

3. Signs. An Owner may not display signs to public view without advance approval from the Architectural Reviewer, except as described below.

- (i) One (1) commercially manufactured sign indicating the residence is for sale or lease may be placed on the applicable Lot without advance approval from the Architectural Reviewer, provided the dimensions do not exceed three (3) feet by two (2) feet;
- (ii) Up to a maximum of two (2) commercially manufactured signs in support of or in opposition to a candidate for public office or a ballot measure, provided the criteria below is met.
 - a. The sign(s) may not exceed two (2) feet in height or width;
 - b. Sign(s) may be displayed no earlier than twenty-one (21) days prior to the date voting takes place for the associated election or ballot measure;
 - c. Any such sign displayed on an Owner's Lot must be applicable to the voting district in which the Lot is located; and
 - d. The sign(s) must be removed within three (3) days after such election date.

Additional rules and standards related to signs are set forth in the Declaration.

V. CONSTRUCTION STANDARDS

A. Condition of Lot. An Owner or builder shall inspect the Lot prior to purchase and construction of Improvements for condition of all utilities, location of property pins, and general conditions and report any defects or damages to the developer. Unless otherwise notified, all Improvements shall be considered in good repair and all damages or deficiencies thereafter shall be the sole responsibility of the Owner or builder.

The developer or its engineer shall relocate missing property pins, utility connections, or sewer markers, that cannot be located by ordinary inspection (including light digging to uncover buried pins or markers) prior to closing or commencement of construction. Resetting property pins or locating pressure irrigation, utility services, or sewer markers after possession will carry a minimum charge of One Hundred and No/100 Dollars (\$100.00) from the developer.

B. Excavation. Excavators are required to contact Dig Line at 208-342-1585 prior to commencing excavation on the Lot. Lots shall be excavated in a manner that will not adversely impact neighboring Lots. Excess dirt shall be removed from the community and may not be deposited or dumped on other Lots, common areas, any portion of the community or any other vacant ground slated for future development.

C. Elevation of Foundations. Unless otherwise approved by the Architectural Reviewer, foundations shall be set a minimum of eighteen inches (18") and a maximum of twenty-four inches (24") above the back of the curb elevation or as may otherwise be specified in the improvement plans approved by the municipality. An Owner or builder shall take all necessary steps in setting the foundation elevation to ensure that drainage onto neighboring properties will be eliminated. All drainage from a Lot will be retained on site or drained into the adjoining street.

The level of groundwater in and near the community is subject to high fluctuation. It is the sole responsibility of the builder and Owner to determine the appropriate elevation(s) for any Improvements constructed on such Lot (e.g. finished floor) and construct proper drainage for the foundation and around the home to ensure that water on the Lot will drain off the Lot in accordance with the grading and drainage plans approved by the City of Star, Idaho.

D. Timeline to Complete Construction. Upon commencement of construction, the construction of the Improvements shall be diligently pursued in accordance with the submittal approved by the Architectural Reviewer, including all conditions of approval. Construction shall be completed within one (1) year from date construction commences. The Architectural Reviewer may require a completion deposit and such funds may be used toward any construction related violations, including to return the Lot to its original condition as described below.

If construction is not completed within one (1) year from the date construction commences and an Owner or builder is not diligently pursuing completion (with no

activity on site for thirty (30) days), the Architectural Reviewer and/or Riverstone HOA shall have the option to require the Owner and/or the builder to return the Lot to its original condition within twenty (20) days. If an Owner and/or builder has not returned the Lot to its original condition within the timeframe required, the Architectural Reviewer and the Riverstone HOA has the right to immediately access the site and return the Lot to its original condition at the Owners and/or builder's expense. Should any applicable completion deposit not be sufficient to cover the associated expense of such corrective action, any remaining amount due shall earn interest at the rate of eighteen percent (18%) per annum and may be assessed against the Owner and/or builder as an Individual Assessment as contemplated by the Declaration.

E. Lot Drainage. The Owner and/or builder are responsible for constructing and/or maintaining proper Lot grading and drainage in accordance with the grading and drainage plans approved by the City of Star, Idaho both during and after any construction, including, but not limited to, landscape. Except as otherwise specified, all water on a Lot shall be directed to the street and/or retained on such Lot, and no Lot is permitted to drain onto an adjacent Lot.

Spoils from excavation are to be removed from the Property; "spinning off" or otherwise distributing spoils across a Lot is not acceptable. Modifications to the approved grading and drainage plans approved by the City of Star will require approval by the Architectural Reviewer prior to modifications taking place. Builder and/or Owner assumes responsibility for such modifications, including, but not limited to, obtaining any and all approvals from the municipality or other applicable authority.

F. Construction Standards and Jobsite Maintenance. It is important to the community and the Declarant that the community experience is a positive one for all builders, contractors, Owners and their guests. In order to facilitate such, any entity and/or individual performing work within the community shall comply with the guidelines set forth below.

1. Washout of concrete trucks and equipment will be performed outside of the subdivision or in a designated concrete washout area. Developer will determine a location and provide direction to the concrete washout area within the community. Contractors are required to utilize this area to clean concrete trucks, pumps, or other concrete coated equipment if washed within the subdivision.
2. Construction shall not begin prior to 7:00 a.m. or continue after sunset; however, during the mid-summer months (June-August), contractors may begin as early as 6:00 a.m. if they are sensitive to Owners and Occupants and comply with all applicable jurisdictional and municipal requirements and laws.
3. Jobsites shall be tidied up and free of debris each evening and prior to each weekend. Each builder shall provide a trash bin and/or dumpster at the jobsite. Jobsite trash or debris that may be scattered by wind shall be properly contained in trash bins and/or dumpsters or by other means. Builders and Owners who fail

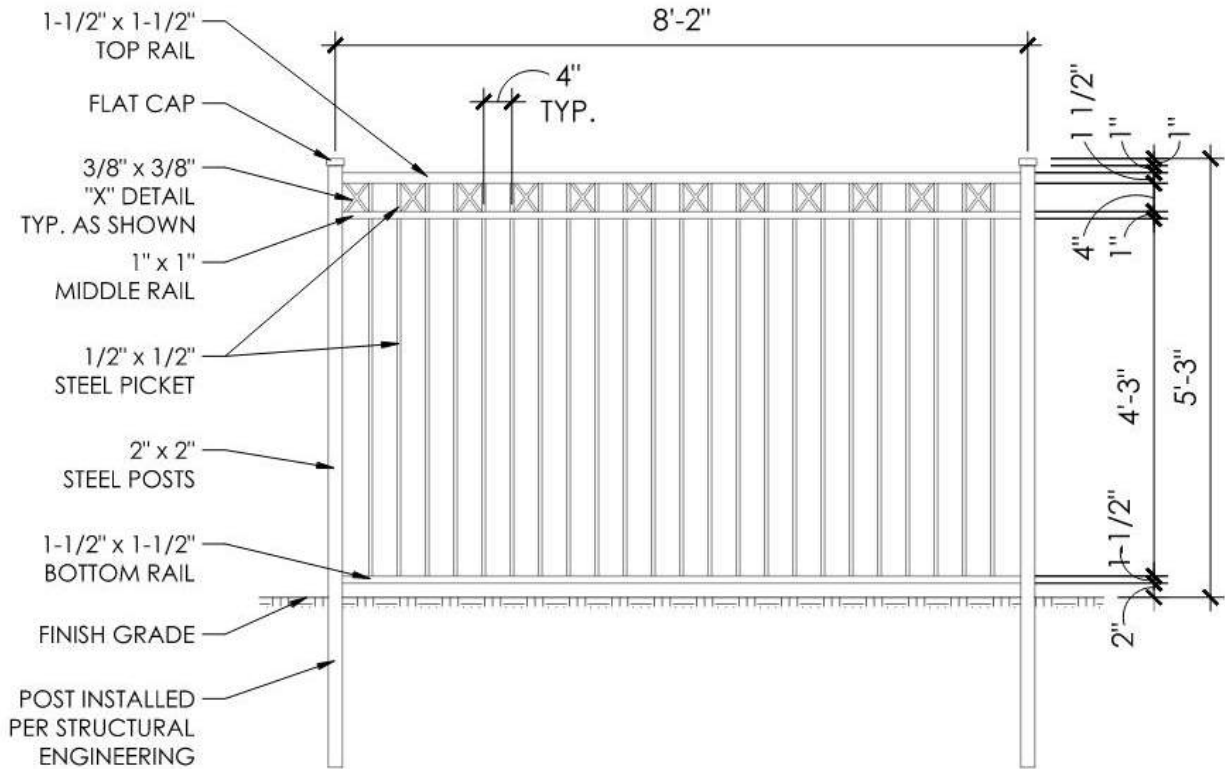
to maintain the Lot in an orderly manner or allow construction debris to clutter surrounding properties may be subject to appropriate action from the Architectural Reviewer or the Riverstone HOA.

4. Temporary toilets, construction equipment, and construction material shall be contained within the Lot boundaries.
5. All vehicles will be parked within the Lot boundaries or on public streets adjacent to the jobsite and shall not block traffic, mailboxes, or otherwise interfere with existing Owners or Occupants.
6. Dogs shall not be allowed at the construction site.
7. Inappropriate language, shouting, or other inappropriate behavior will not be allowed.
8. Radios or other music must be kept to a minimum volume and should not be audible outside of the Lot limits.
9. Power and water must not be used from existing residences without permission from the Owner.
10. All personnel shall comply with the maximum speed limit within the community. Speeding or unsafe driving will not be tolerated.
11. Streets shall remain free from dirt, gravel, or other excavation material and shall be maintained by the Owner or builder in a clean and orderly manner. Washing of equipment or materials may not occur in the street or any common areas.
12. Materials or equipment may not be stored on any other Lot or common area. Access to a Lot across any other Lot or common areas is prohibited.
13. Contractors shall always be fully clothed, including, but not limited to, shirts and footwear. Notwithstanding the foregoing, attire shall be appropriate for the work being performed.
14. Appropriate safety equipment including, but not limited to, hard hats, safety eyewear, and high visibility clothing, shall be used while work is being performed.
15. No fires are permitted anywhere in the community for the purpose of construction.
16. At their own discretion, builders may seek a temporary right-of-way use permit from the City of Star, Idaho to temporarily block the sidewalk in front of a residence under construction. Please refer to the City of Star, Idaho for more information and specific requirements.

G. Complaints. Any complaints will be conveyed to the applicable builder or Owner, and each builder or Owner will be held responsible by the Architectural Reviewer to ensure their contractors and subcontractors remain compliant with these Design Guidelines at all times.

**EXHIBIT A.
VIEW FENCE**

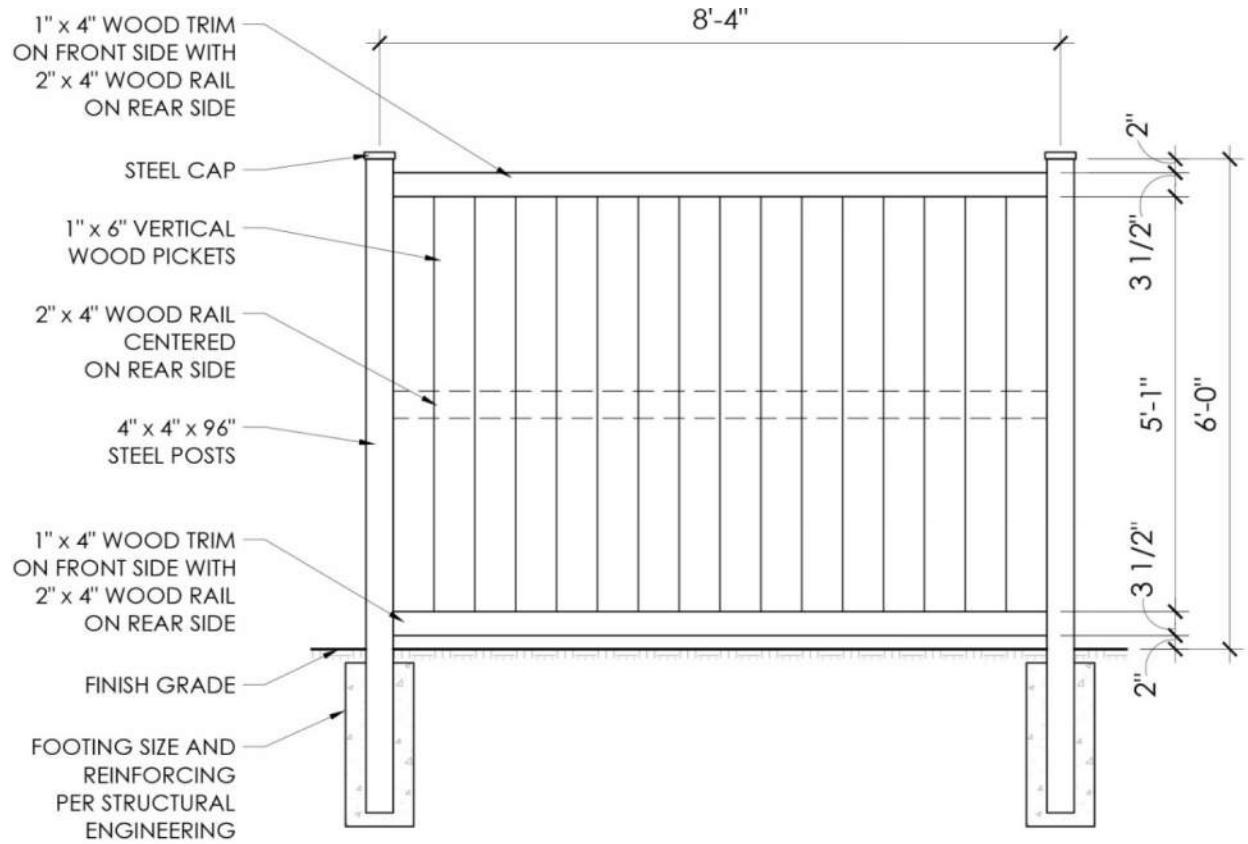
Manufacturer: Boise River Fence
Product: M3 Wrought Iron



NOTE:
 ALL METAL TO BE FINISHED WITH POWDER COAT COLOR "RUST TEXTURE
 T091-BR47" BY CARDINAL.

**EXHIBIT B.
BUILDER/OWNER SCREEN FENCE**

Manufacturer: Boise River Fence
Product: M3 Custom Picture Frame Cedar with Steel Posts

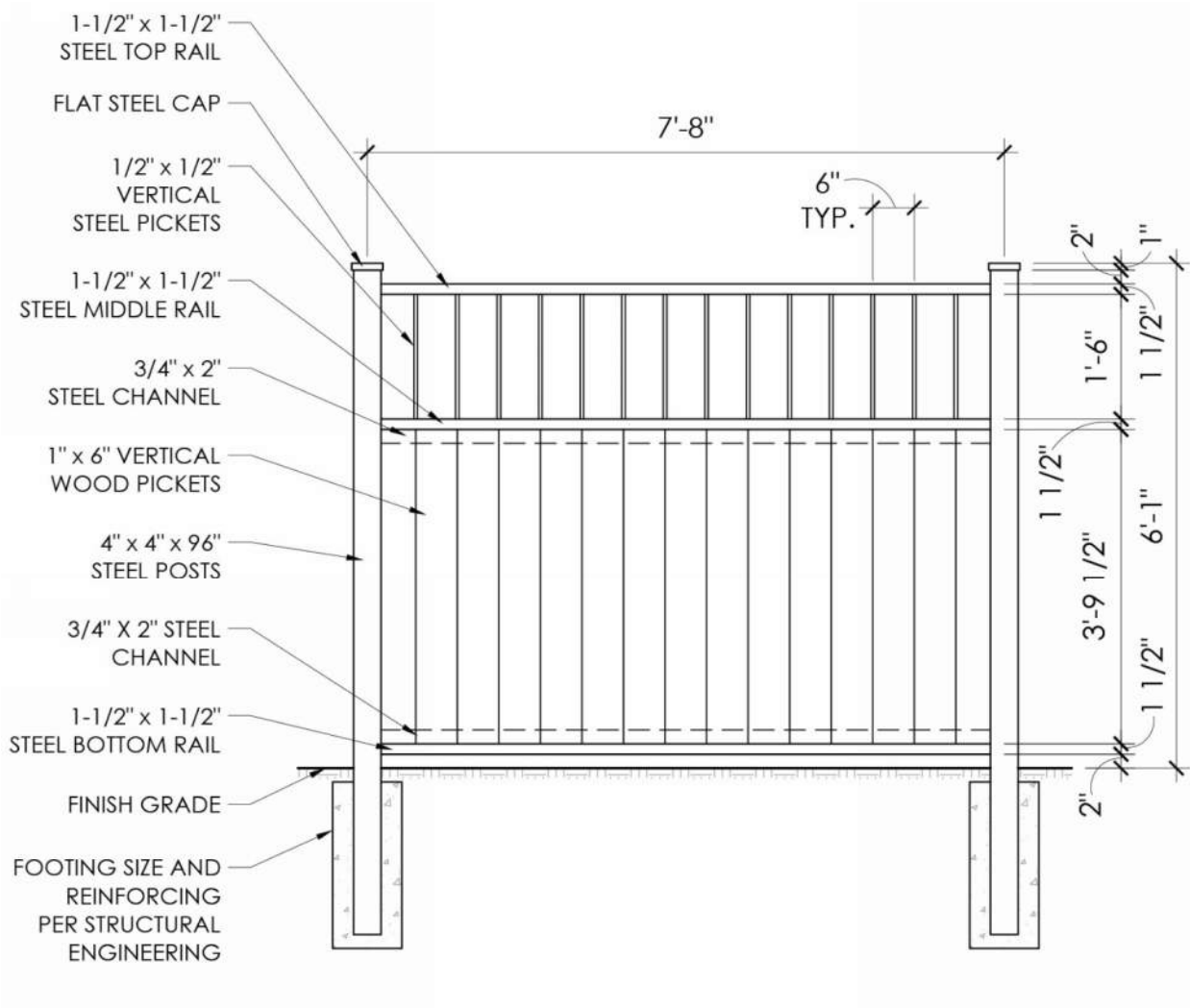


NOTES:

1. ALL METAL TO BE FINISHED WITH POWDER COAT COLOR "RUST TEXTURE T091-BR47" BY CARDINAL.
2. ALL WOOD TO BE STAINED WITH STAIN COLOR "PECAN" BY READY-SEAL.

**EXHIBIT C.
DEMI-SCREEN FENCE**

Manufacturer: Boise River Fence
Product: M3 Picket Top Privacy 2.0

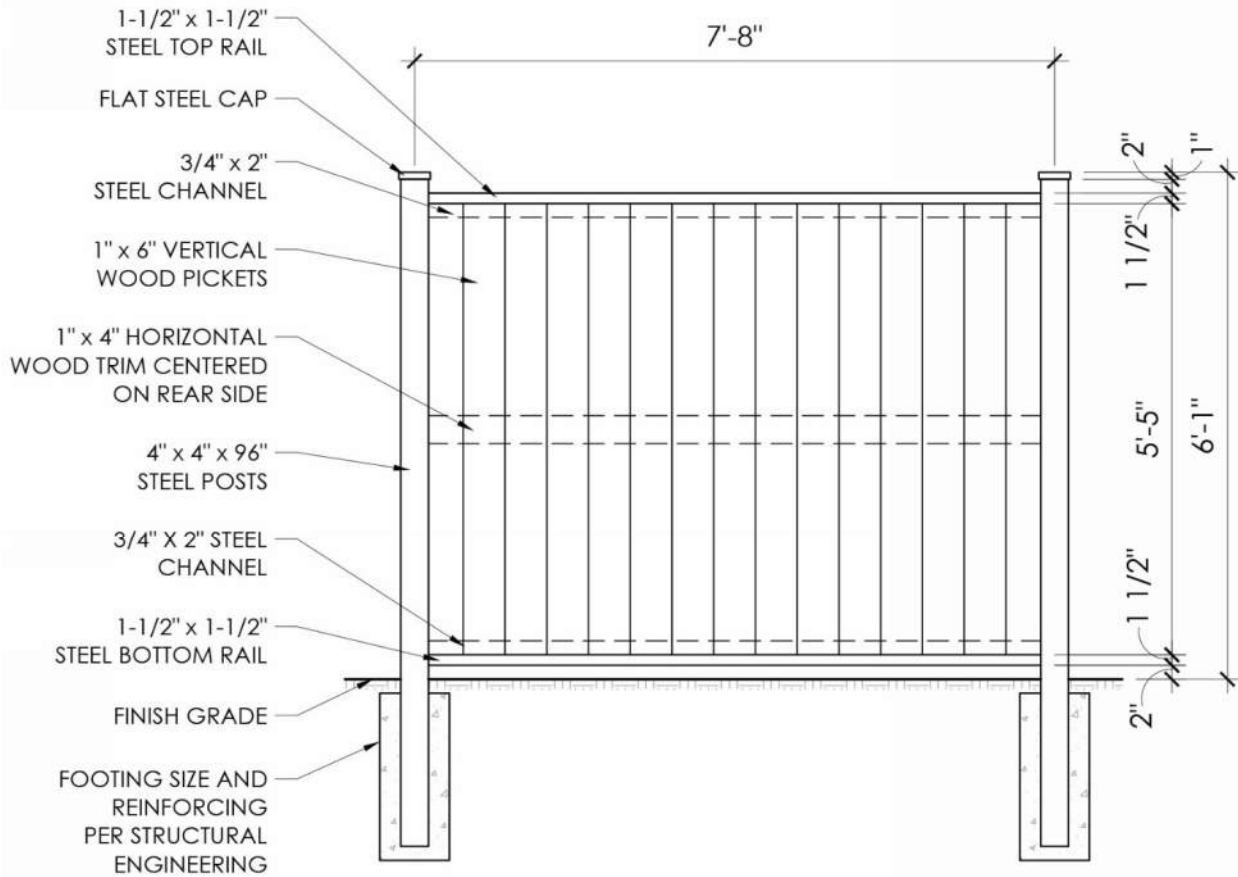


NOTES:

1. ALL METAL TO BE FINISHED WITH POWDER COAT COLOR "RUST TEXTURE T091-BR47" BY CARDINAL.
2. ALL WOOD TO BE STAINED WITH STAIN COLOR "PECAN" BY READY-SEAL.

**EXHIBIT D.
DEVELOPER SCREEN FENCE**

Manufacturer: Boise River Fence
Product: M3 Vertical Privacy 2.0



NOTES:

1. ALL METAL TO BE FINISHED WITH POWDER COAT COLOR "RUST TEXTURE T091-BR47" BY CARDINAL.
2. ALL WOOD TO BE STAINED WITH STAIN COLOR "PECAN" BY READY-SEAL.



**EXHIBIT E.
FENCE PLAN BY PHASE**





LEGEND

- | | | |
|---|--|--------------------------------------|
| N | | SCREEN FENCE BY OWNER / BUILDER |
| ↑ | | SCREEN FENCE BY DEVELOPER |
| ↑ | | DEMI-SCREEN FENCE BY OWNER / BUILDER |
| ↑ | | DEMI-SCREEN FENCE BY DEVELOPER |
| ↑ | | VIEW FENCE BY OWNER / BUILDER |
| ↑ | | VIEW FENCE BY DEVELOPER |

RIVERSTONE SUBDIVISION 2 FENCE PLAN
NOT TO SCALE

v4



LEGEND

- SCREEN FENCE BY OWNER / BUILDER
- SCREEN FENCE BY DEVELOPER
- DEMI-SCREEN FENCE BY OWNER / BUILDER
- DEMI-SCREEN FENCE BY DEVELOPER
- VIEW FENCE BY OWNER / BUILDER
- VIEW FENCE BY DEVELOPER



RIVERSTONE ESTATES SUBDIVISION FENCE PLAN
NOT TO SCALE



RIVERSTONE SUBDIVISION 3 FENCE PLAN
NOT TO SCALE

EXHIBIT F.
DIRECT ENTRY LAKE FRONT LOTS BY PHASE

Subdivision 1 – No Lake Front Lots will have direct entry to a lake.

Subdivision 2 – No Lake Front Lots will have direct entry to a lake.

Subdivision 3 – Does not include any Lake Front Lots.

Estates Subdivision – No Lake Front Lots will have direct entry to a lake.

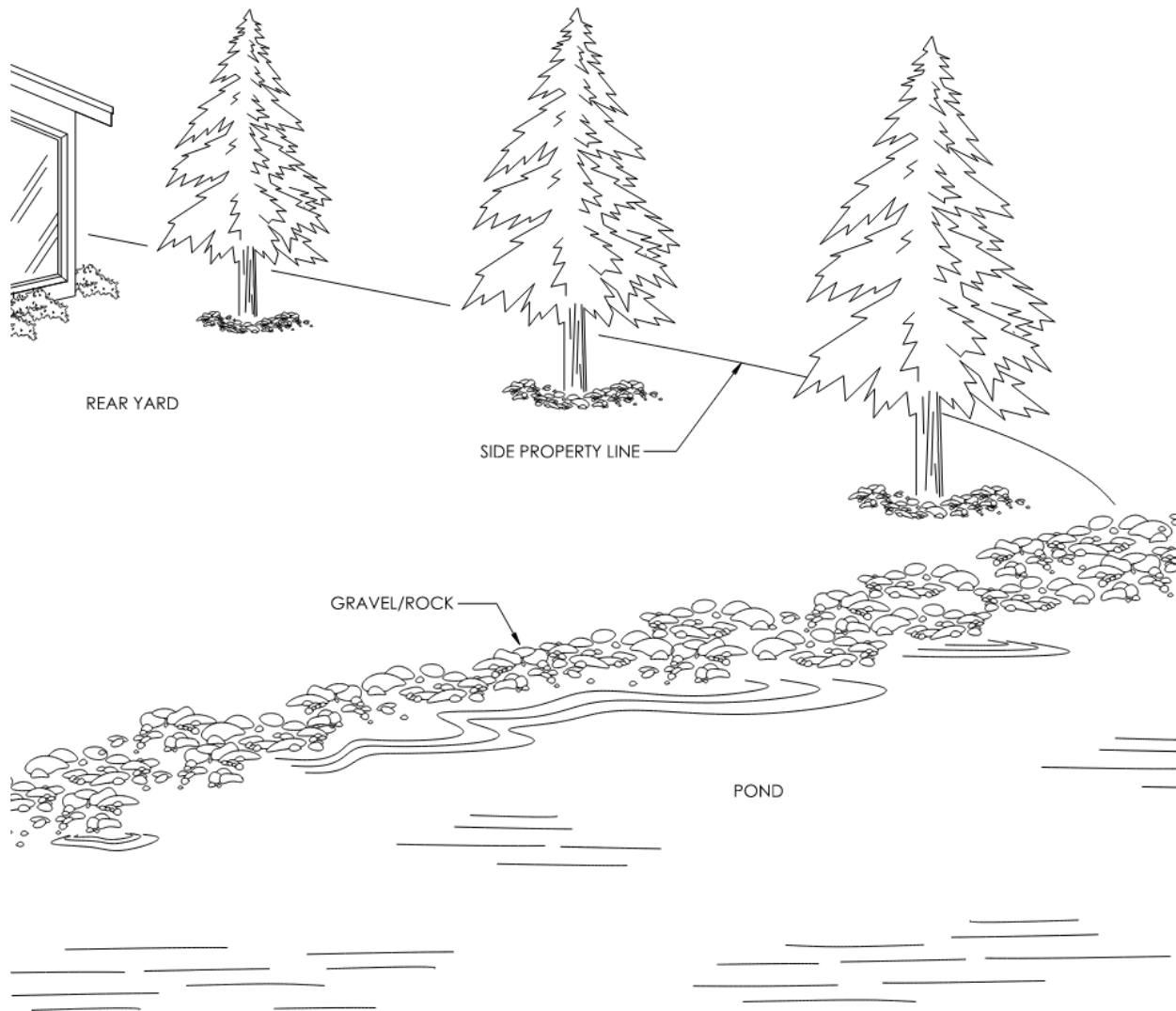
EXHIBIT G.
ROCK COLOR/TYPE & BOULDER WALL DESIGN EXAMPLES

Rock chips, rip-rap, and boulders, including boulders used for retaining, are to match or be substantially similar to the rock color/type shown below. Additionally, boulder retaining walls shall be substantially similar in design and appearance as those constructed below.

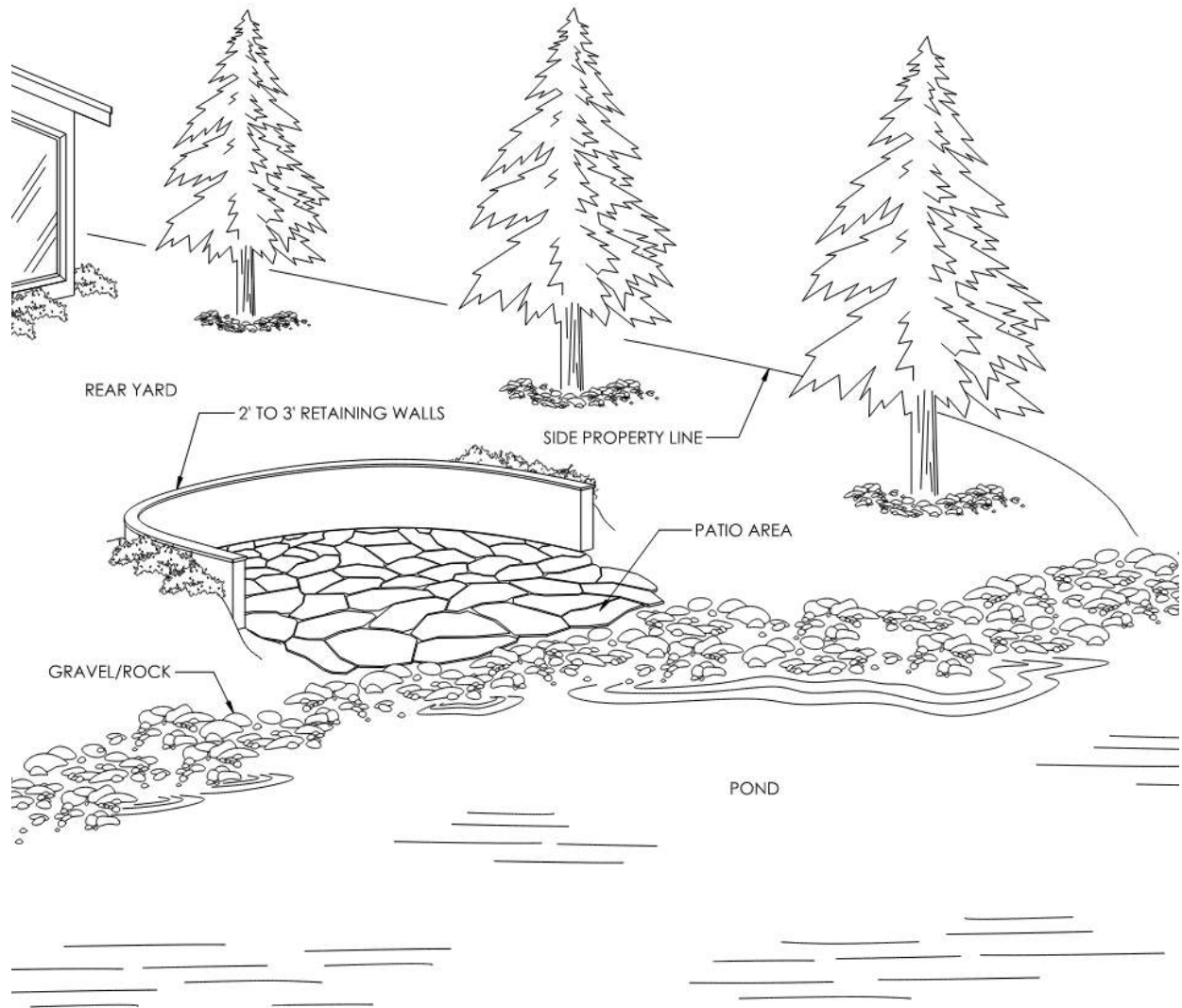


EXHIBIT H.
LAKE EDGE IMPROVEMENTS

Cobble Along Edge of Water



Recessed Patio by Water's Edge



Recessed Sand "Beach" at Water's Edge

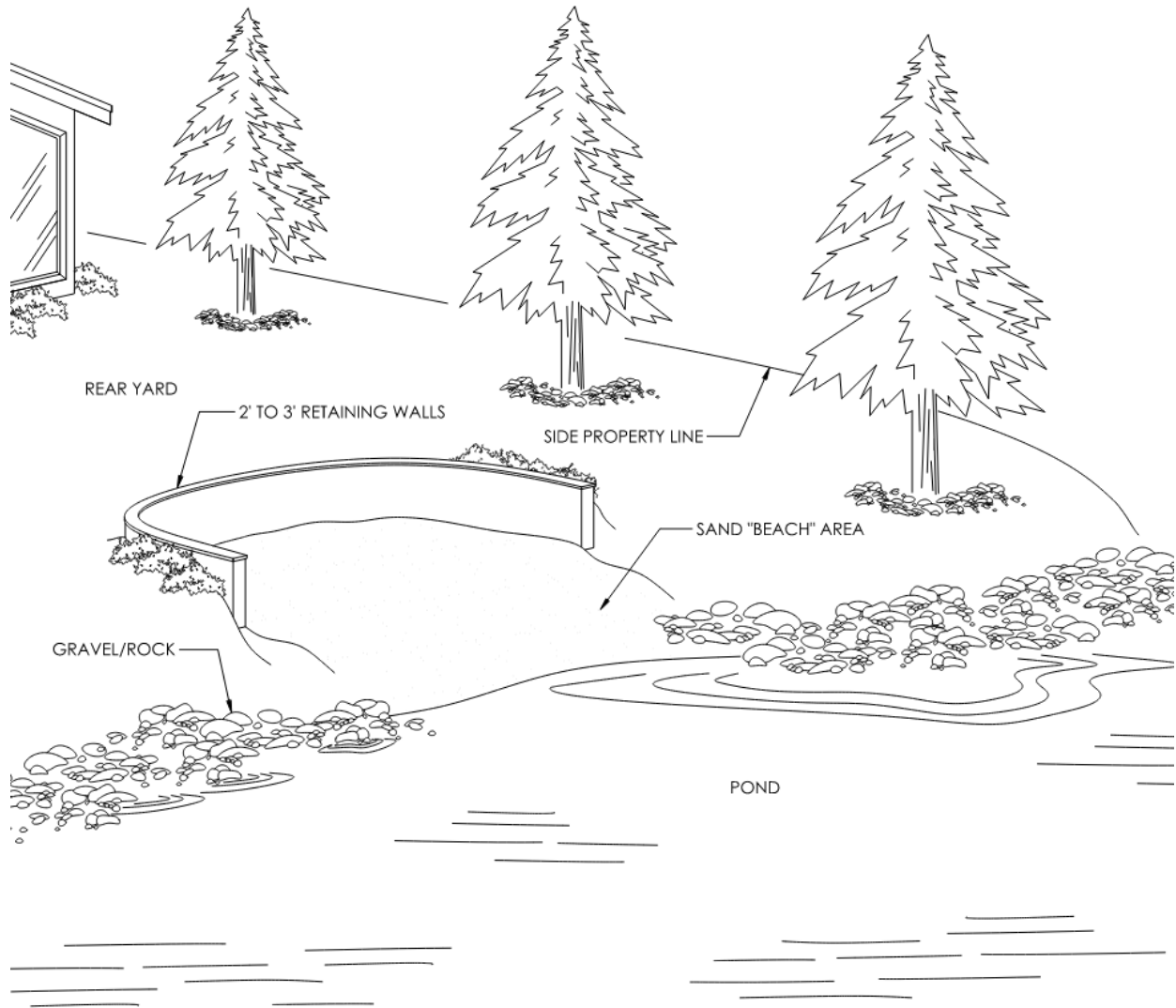
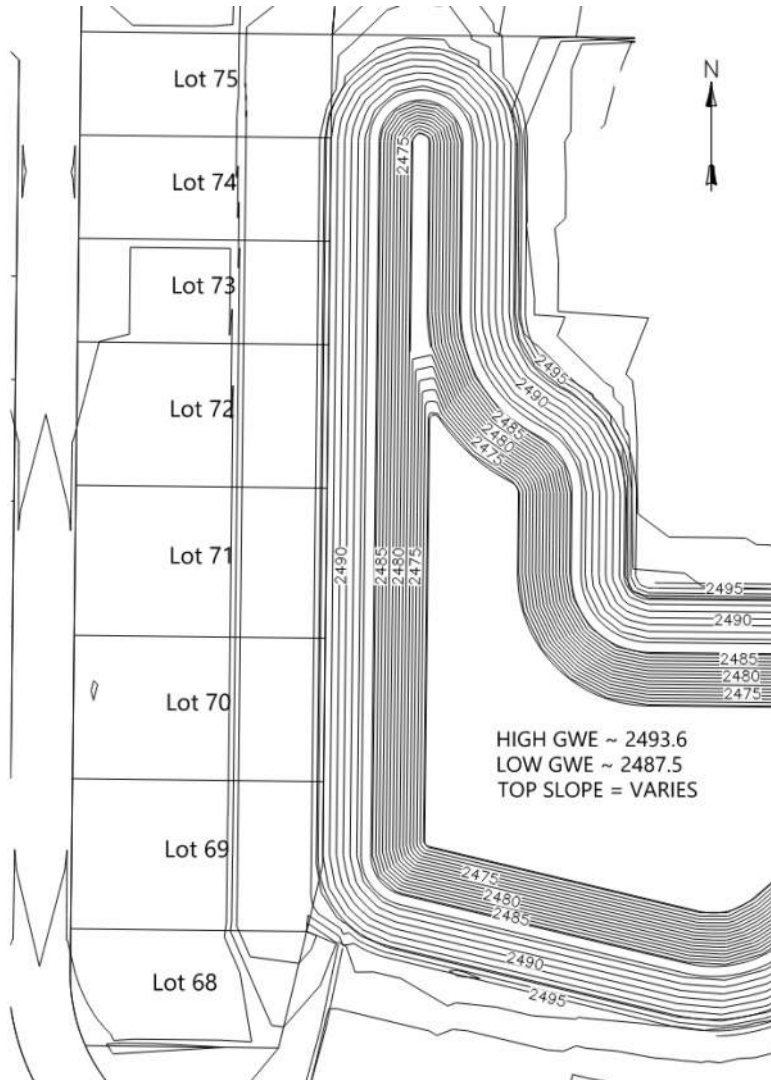


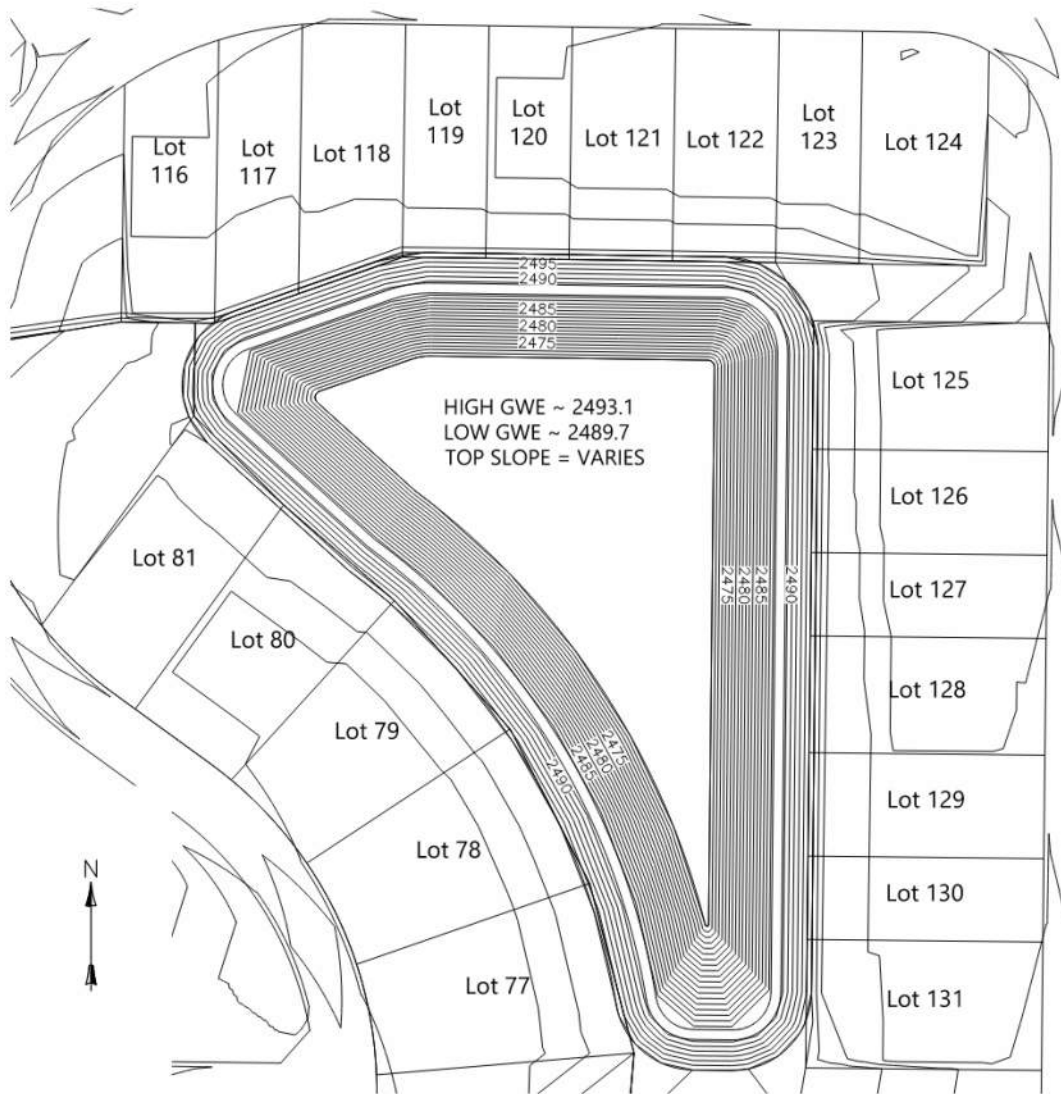
EXHIBIT I.
POND WATER LEVEL ILLUSTRATIONS & TYPICAL CROSS-SECTION

POND D – Subdivision 1 Lots 69-75



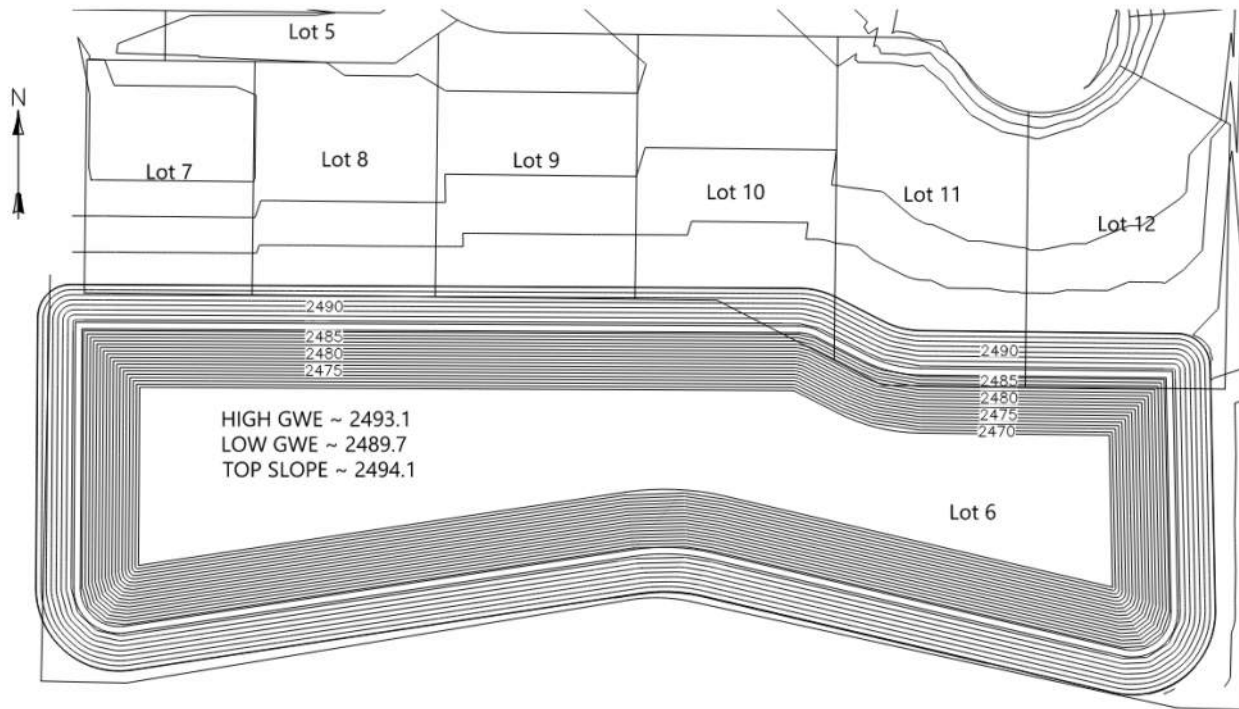
*Illustrative use only. Water levels shown are approximate.
Actual water levels and conditions will vary and are subject to change over time.*

POND C – Subdivision 1 Lots 77-81, Subdivision 2 Lots 116-131



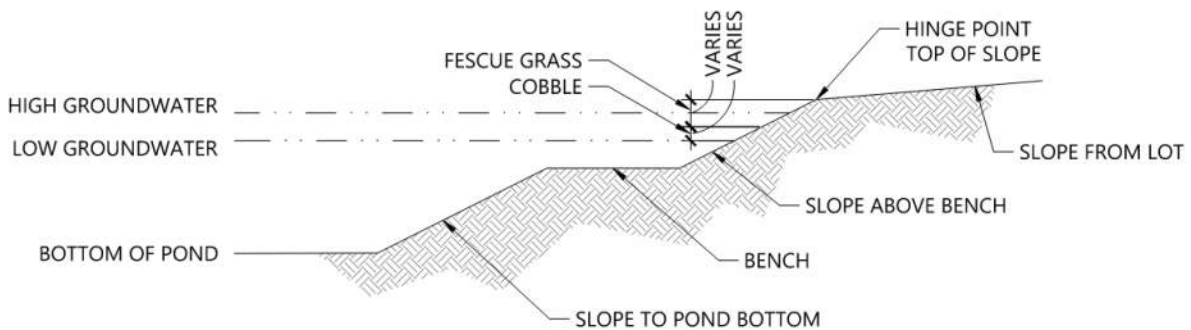
*Illustrative use only. Water levels shown are approximate.
Actual water levels and conditions will vary and are subject to change over time.*

POND C – Subdivision 1 Lots 77-81, Subdivision 2 Lots 116-131



*Illustrative use only. Water levels shown are approximate.
Actual water levels and conditions will vary and are subject to change over time.*

TYPICAL CROSS-SECTION - ALL PONDS



ATTACHMENT 1.
APPLICATION FOR DESIGN REVIEW

Part 1 - Design Review Application

Date: _____

Submittal Type:

- | | |
|--|--|
| <input type="checkbox"/> Initial Design Review Submittal | <input type="checkbox"/> Substantially Revised Submittal |
| <input type="checkbox"/> Alteration Submittal | <input type="checkbox"/> Other: _____ |

Owner / Builder Information:

Builder _____	Email _____	Phone _____
Address _____		Zip _____
Owner _____	Email _____	Phone _____
Address _____		Zip _____

Site Information:

Lot/Block Number _____ Street Address _____
Lot Area (SF): _____ Lot Width at Front Setback _____

Lot Type:

- Small ($\leq 55'$ wide)
- Large ($> 55'$ and $< 86'$ wide)
- Estate ($\geq 86'$ wide)
- Cluster

Lot Size:

- $< 5,000$ SF
- $5,000$ SF to $12,000$ SF
- $> 12,000$ SF

Proposed Plan Information:

Building Height _____ Number of Stories _____ Plan Name or #: _____

Total Square Feet (SF) Under Roof:

First Floor _____
Second Floor _____
Other _____
Total _____

Finished (Livable) Square Feet (SF):

First Floor _____
Second Floor _____
Other _____
Total _____

Exterior Materials and Colors:

Roof _____
Main Body _____
Windows/Doors _____
Garage Door _____
Fascia _____
Stone/Brick _____
Trim _____
Other _____

Part 2 – Design Review Checklist

Each of the items listed below must be submitted along with this completed Application. This is not a complete list of submittal requirements; please refer to the applicable section of the Design Guidelines for specific guidelines and submittal requirements. The Architectural Reviewer may request additional information at its sole discretion, and no submittal is considered complete until all requested items have been received.

- 1. Application. Each submittal shall be accompanied by this completed Application.
- 2. Site Plan - Show the Lot boundary, the proposed location of all Improvements (including, but not limited to, all structures, driveways, sidewalks, fences, patios, outdoor lighting, etc.), all easements, and all proposed setbacks. Include a roof plan as part of the site plan if a separate roof plan is not submitted. Use arrows to indicate the proposed grading and drainage flow directions off the Lot away from the adjacent Lots. (Minimum scale of 1/8" = 1'-0".)
- 2. Grading Plan - Overlay the proposed grades over the existing grades on a Lot plan showing all boundaries, easements, and applicable setbacks. Use arrows to indicate the proposed grading and drainage flow directions off of the Lot and away from adjacent Lots. (Minimum scale of 1/8" = 1'-0".)
- 3. Roof Plan(s) - Depict masses, ridgelines, and roof pitches and include pertinent dimensions (e.g. gable span, overhang depths) if not provided elsewhere. Show the locations of any roof drains or scuppers, as applicable. The roof plan may be included on the site plan in lieu of a separate roof plan. (Minimum scale of 1/8" = 1'-0".)
- 4. Floor Plan(s) - Include the per floor square feet and total finished square feet of the residence, exclusive of garages, covered patios, storage areas, etc. Show exterior residential lighting locations and specifications. Provide exterior dimensions on all plans. (Minimum scale of 1/4" = 1'-0".)
- 5. Building Elevations - Illustrate front, rear and side views, showing the maximum building height and include proposed exterior finish material descriptions. (Minimum scale of 1/8" = 1'-0".)
- 6. Specifications - Include the specifications and descriptions of any proposed exterior materials, finishes, equipment, etc.
- 7. Exterior Materials and Colors - Provide exact color samples of proposed exterior material colors, (e.g. paint, stain). Samples of all other materials (e.g. brick, stone) shall be shown on the elevations. All proposed exterior materials and colors shall be identified by name, number, color, and manufacturer.
- 8. Landscape Plan - Show the proposed landscape layout including elevations and dimensions as applicable, along with any proposed fencing, landscape lighting, and a legend of the plant types, sizes, and quantities. Use arrows to indicate the proposed grading and drainage away from the proposed residence and adjacent Lots. It is preferred that the landscape plan be submitted with the initial submittal, but it may be submitted up to sixty (60) days after the initial submittal. (Minimum scale of 1/8" = 1'-0".)
 - Please mark this box if the landscape plan will be submitted separately.
- 9. Design Review Fee – If not already paid, include the applicable design review fee, and mark the box below indicating the applicable fee type pursuant to *Section II.A.10*.
 - Initial design review fee - \$350
 - Additional design review fee - \$150